

Sears
owners
manual

Provided By:
WheelHorse.org

MODEL NO.
917.251880

CAUTION:
Read Rules for
Safe Operation
and Instructions
Carefully

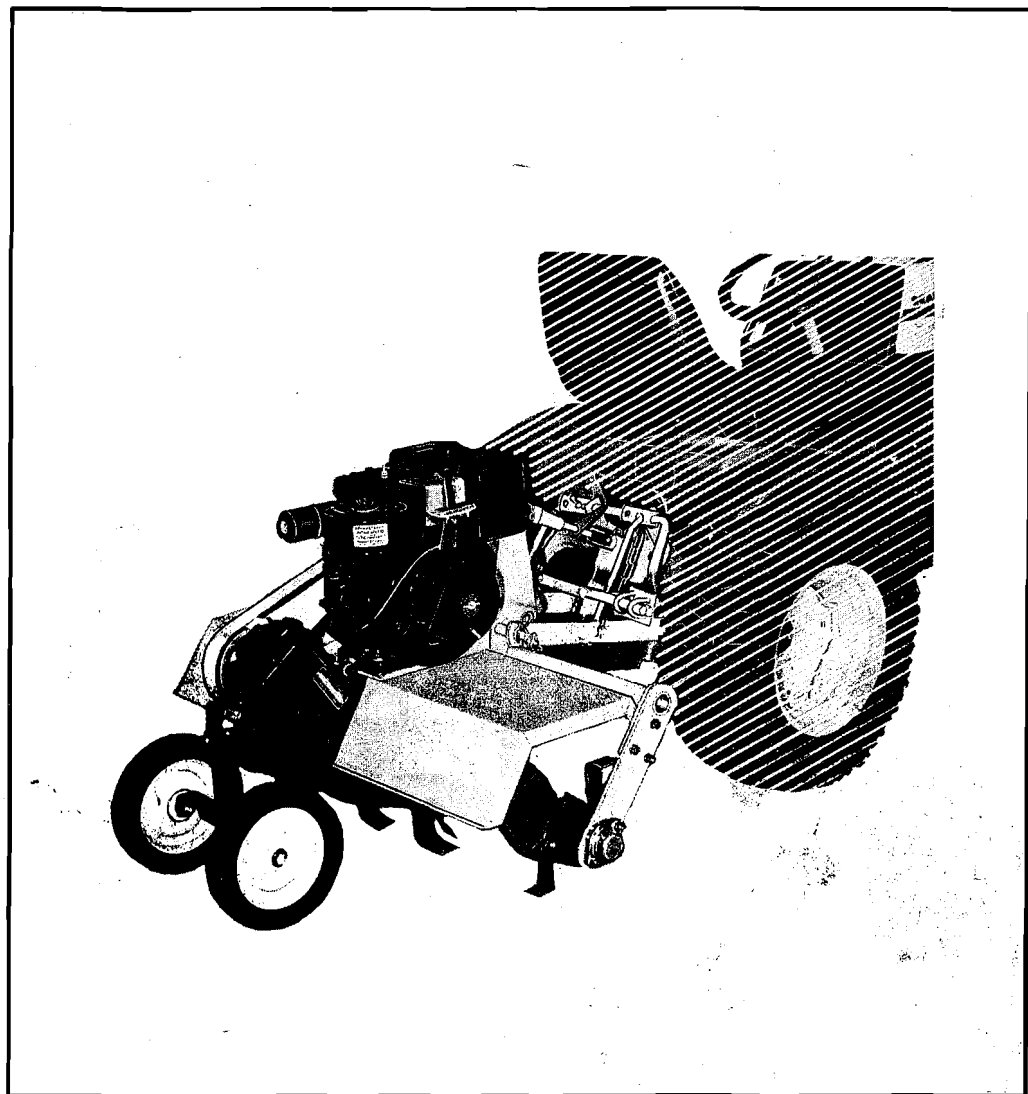

ROTO-SPADER ATTACHMENT

- **Assembly**
- **Operation**
- **Maintenance**
- **Repair Parts**

Sears, Roebuck and Co., Chicago, Ill. 60684 U.S.A.
and Simpsons Sears Limited, Toronto



GUARANTEE

During the first 90 days, we will repair your Roto-Spader Attachment, free of charge, if defective in material or workmanship.

In addition, during the first year, we will replace any broken tines, free of charge.

This guarantee service is available by simply contacting any of our stores or service centers throughout the United States or Canada.

If the Roto-Spader Attachment is used for commercial or rental purposes, this guarantee is limited to 30 days.

SEARS, ROEBUCK AND CO., CHICAGO, ILL. 60684 U.S.A.
and SIMPSONS-SEARS LIMITED, TORONTO

SAFETY PAYS OFF

IMPORTANT

read rules for safe operation

1. Know the controls, and how to stop quickly. Read the Owner's Manual thoroughly.
2. Do not allow children to operate your tractor and Roto-Spader attachment. Do not allow adults to operate them without proper instruction.
3. Keep children and pets a safe distance away.
4. Clear work area of objects which might be caught in tines.
5. Before starting the engine, be sure clutch is disengaged, and tines are clear.
6. Make sure of your footing and stand clear of tines when starting engine.
7. Do not run engine indoors, because the engine-exhaust fumes contain carbon monoxide, which is a tasteless, odorless, deadly poison.
8. Check fuel supply before each use. Never remove the gas cap or fill the gasoline tank when engine is running or while it is hot. When filling the fuel tank, leave space for expansion; do not fill it to the brim and keep in mind that the heat of the sun can cause the gasoline to expand. Wipe off any spilled gasoline before starting the engine. Remember, gasoline is highly flammable and must always be handled with extreme care.
9. Stop tractor, disengage Roto-Spader attachment clutch and stop Spader and tractor engines. Shift tractor to neutral position, set parking brake, and remove ignition key before leaving operator's position.
10. Never stand near tines or work on tines when engine is running.
11. Watch for traffic when crossing or near roadways.
12. Always disengage Roto-Spader clutch, and stop engine when travelling to and from field or when not tilling.
13. Lift Spader attachment out of the ground when turning corners.
14. Do not put tractor in reverse gear while Spader is in the ground.
15. Keep all nuts, bolts and screws tight in order to be sure that the tractor and attachment are in safe working condition. Be sure the brake and all powered attachment controls are always in proper adjustment and repair. Check the attachment and engine mounting bolts at frequent intervals for proper tightness. Before performing any maintenance, always disengage the power to attachment, set the parking brake, shift into neutral, shut off the engine, make absolutely sure the Spader attachment and all moving parts have completely stopped, remove ignition key, disconnect the spark-plug wire from the spark plug and keep it away from the plug to prevent injury or accidental starting. The only exception to this rule is carburetor adjustment.
16. Keep the engine free from accumulations of grass, leaves or excessive grease, as these accumulations are combustible and could result in a fire. Always keep your Roto-Spader attachment in good operating condition and make sure that all shields, guard plates and all other protective devices are in place. Give your Spader attachment the regular maintenance it needs and have a competent service technician make a thorough inspection of it at least once a year.
17. Do not store your Roto-Spader attachment for prolonged periods (more than 30 days) with gasoline in the tank. Do not store your Spader attachment or a gasoline container inside a building where fumes may reach an open flame or spark; they should be stored in a cool, dry place. Be sure to let the engine cool before storing in any enclosure. Always use an approved gasoline container for storing gasoline and keep your Spader attachment and gasoline container in locked storage to prevent children from playing and tampering with them.

TABLE OF CONTENTS

GUARANTEE	Inside Front Cover
RULES FOR SAFE OPERATION	1
ASSEMBLY INSTRUCTIONS	2-4
OPERATION INSTRUCTIONS	5-6
MAINTENANCE INSTRUCTIONS	6-9
REPAIR PARTS	10-19

INTRODUCTION

This Roto-Spader has been designed, engineered and manufactured to give you the best possible dependability and performance.

Should you experience any problem you cannot easily remedy, please contact your nearest Sears, Roebuck and Co. or Simpsons-Sears, Ltd. store. They have well-qualified, competent, trained technicians and the proper tools to service or repair your Spader. It is important that the operator **ALWAYS OBSERVE THE "RULES FOR SAFE OPERATION"** as well as other instructions contained in this Manual. We have provided this Manual to help operate your Spader with utmost efficiency. We urge you to study this Manual so you will understand your new Spader thoroughly before operating it. We suggest that you take care of your Manual so that it will be available for future reference.

DO THIS FIRST

1. Cut all four corners of shipping carton down from top to bottom.
2. Cut all wires which fasten Spader to wood pallet on bottom of carton.
3. Remove Spader, bag of hardware and all parts from carton.
4. **IMPORTANT:** Check oil level in transmission and fill to level of oil filler plug, if necessary. Use S.A.E. 30 motor oil MS, SC, SD or SE. To fill the transmission, use a small-flexible neck funnel. Refer to Figure 7 for location of filler plug.

5. Fill engine crankcase to overflowing with S.A.E. 30 oil, API rating MS, SC, SD or SE. Because of recent changes in the classifications, the oil container may show one or a combination of these recommended classifications. Capacity: About 2 $\frac{3}{4}$ pints. Refer to Figure 7 for location of engine fill plug.

READ YOUR OWNER'S MANUAL CAREFULLY.

TOOLS AND ITEMS NEEDED

The following is a list of all the tools and supplies needed to assemble and initially service your Spader Attachment.

- 1 Wrench (open or box end) 9/16

ASSEMBLY INSTRUCTIONS

A letter in parentheses in the following instructions refers to an arrow in the adjoining Figure (illustration), except when otherwise stated. When "R.H." (Right Hand) or "L.H." (Left Hand) is used, it should be understood to mean as if one were seated on the tractor seat facing forward.

Your Spader has been shipped from the factory partially assembled for shipping purposes. Open the bags of parts at this time. The contents of the bags of parts are as follows:

- 1 - Owner's Manual
- 1 - Lift link and stop—L.H. (D, Figure 1A)
- 1 - Lift link and chain—R.H. (Z, Figure 1A)
- 5 - Retainer springs (1 on each end of D, and one at L, Figure 1A)
- 1 - Clevis (J, Figure 1A)
- 1 - Rivet (K, Figure 1A)
- 1 - Lift handle extension (V, Figure 1B)
- 1 - U-Bolt plate (X, Figure 1B)
- 2 - U-Bolts (X, Figure 1B)
- 4 - Locknuts (Y, Figure 1B)

REFERENCE DRAWING FOR ASSEMBLY AND INSTRUCTIONS

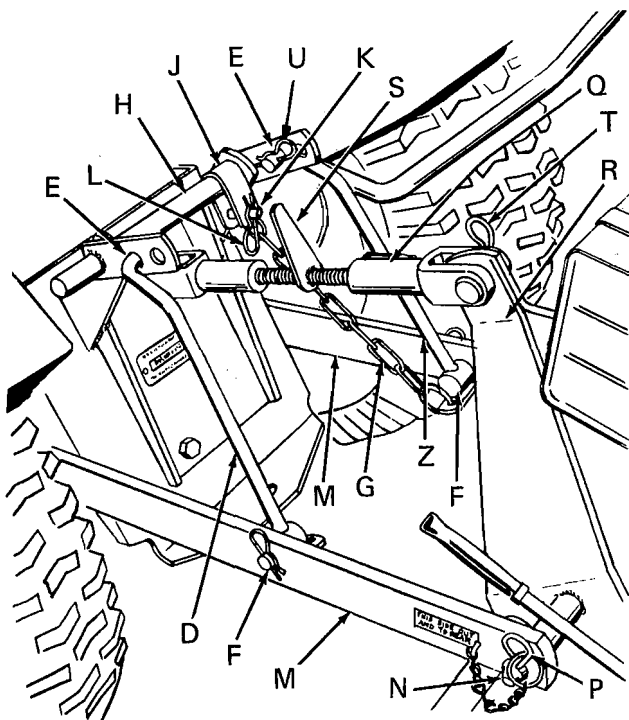

FIG. 1A

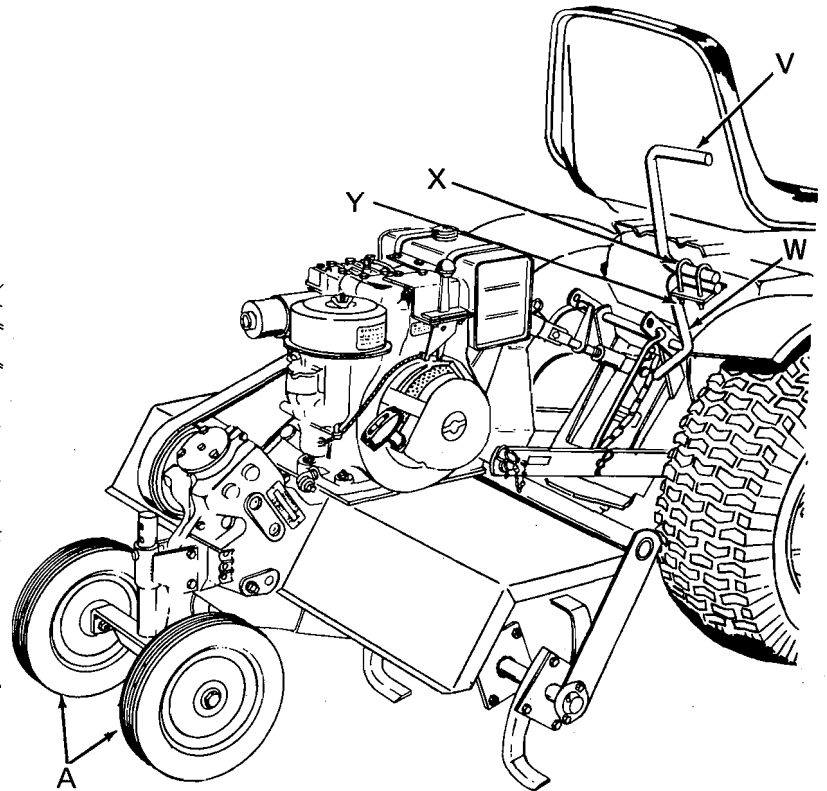

FIG. 1B

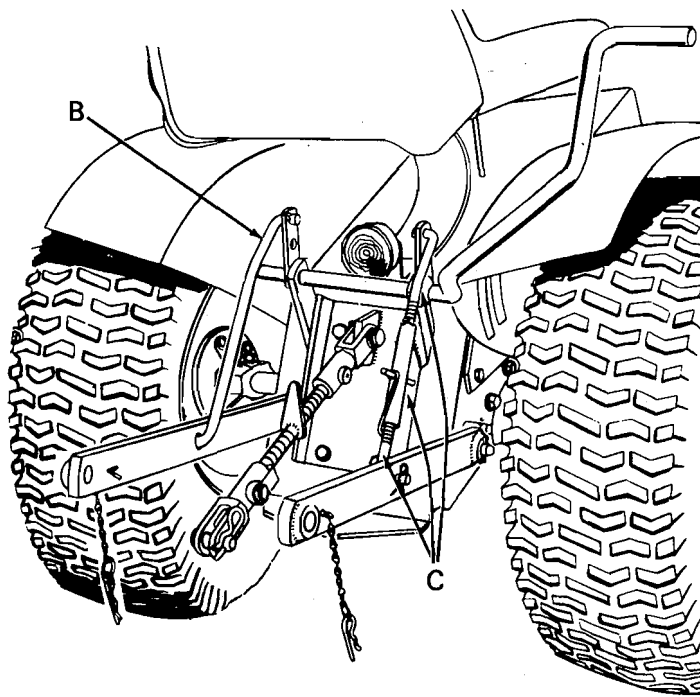

FIG. 2

1. Place Spader on level ground where tractor can be backed up to Spader for assembly. Adjust Spader gauge wheels (A) so that engine is level. Refer to "Tilling Depth," page 5, for adjusting instructions.

2. Remove the following items from the three-point hitch. Refer to Figure 2.

Lift link--L.H. (B)

Lift link upper--R.H., turnbuckle and lift link lower R.H. (C), assembled together.

Save the above parts for future use of 3-point hitch with other attachments.

3. Refer to Figure 1A. Assemble the floating-type lift links (D) & (Z) (included in bag of parts to inner holes (E) of each lever, as shown. Secure with retainer springs (U). NOTE: Offset end of links must be to top and positioned in the lower two holes, as shown.

4. Assemble lift-link swivel (F) to lower lift arms as shown and secure with retainer springs. Refer to Figure 1A.

5. With lift lever in forward (raised) position, attach limit chain (G) to lift-lever cross-shaft (H) with clevis (J). Secure with rivet (K) and retainer spring (L). Refer to Figure 1A
6. Back tractor up to Spader and attach rear of bottom links (M) to pin (N) on Spader and secure with retainer spring (P). Refer to Figure 1A.
7. Assemble clevis (Q) to hitch bar (R).

NOTE: It may be necessary to adjust adjusting screw and handle (S) to assemble clevis (Q) to hitch bar (R), and to keep Spader level. Secure with retainer spring (T).

8. Assemble lift handle extension (V) to lift lever (W) with U-bolts, plate and locknuts (X). Tighten nut securely. Refer to Figure 1B.

INSTRUCTIONS BEFORE OPERATION

WARNING TO PURCHASERS OF INTERNAL-COMBUSTION ENGINE-EQUIPPED MACHINERY OR DEVICES IN THE STATE OF CALIFORNIA

The equipment which you have purchased does not have a spark arrester. If this equipment is used on any forest-covered land, brush-covered land or grass-covered, unimproved land in the state of California, before using on such land, the California law requires that a spark arrester be provided. In addition, such spark arrester is required by law to be in effective working order. The spark arrester must be attached to the exhaust system and comply with Section 4442 of the California Public Resources Code.

FUEL SHUT-OFF VALVE

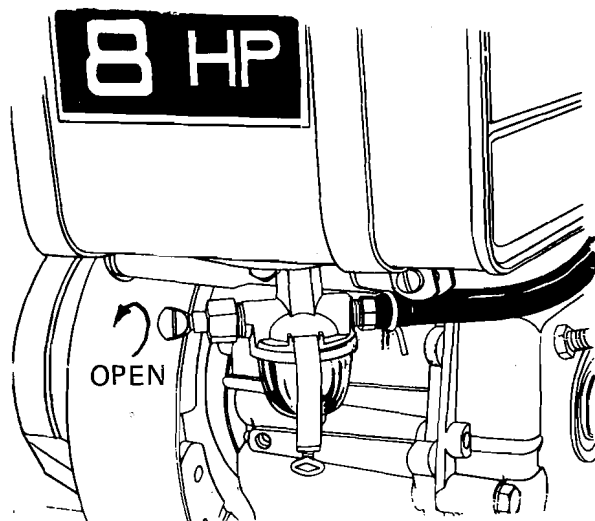

FIG. 3

1. Check oil level in transmission and engine. Transmission capacity: 1½ quarts; oil should be to level of filler hole. Engine capacity: Approximately 2¾ pints. Fill to overflowing. NOTE: Spader must be level. Fill fuel tank with clean, fresh, regular-grade gasoline. Capacity: 1 gallon. Wipe off any spilled fuel and oil.

NOTE: There are two (2) grease fittings on your Spader. One at each outboard bearing. Use Multipurpose Pressure Gun Grease. Fill until grease comes out the inner end of bearings. Grease every eight (8) hours. Figure 7, page 5.

2. Lift Spader with 3-point hitch. Be sure Spader clutch lever is disengaged (lever pulled down). Refer to Figure 14.
3. Open fuel shut-off valve. Shut off this valve after each day's operation. Refer to Figure 3.

HOW TO START AND STOP

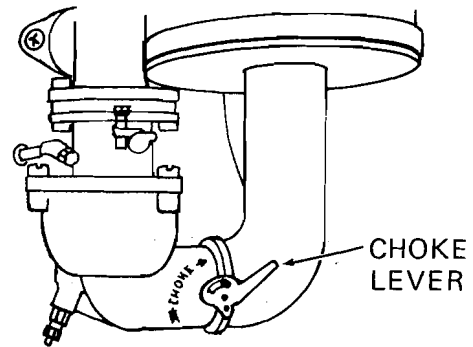

FIG. 4

1. To start a cold engine, move manual choke control to full choke position; refer to Figure 4.
2. Place throttle control in RUN position.

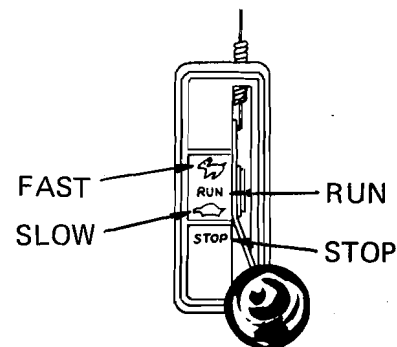

FIG. 5

3. Grasp recoil starter handle and pull sharply. DO NOT allow starter rope to snap back. Rewind slowly, keeping hold of the starter handle at all times, as shown in Figure 6.

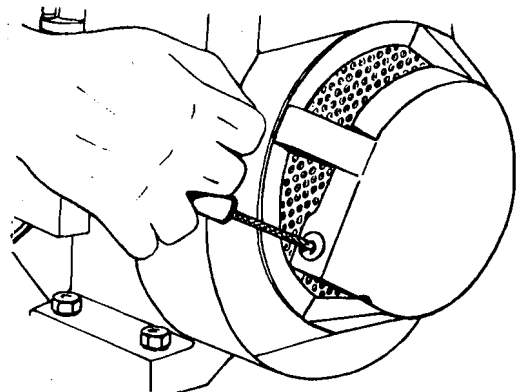

FIG. 6

4. As engine warms up and begins to operate evenly, advance choke control to $\frac{1}{2}$ position and then to NO CHOKE. If engine falters, return to $\frac{1}{2}$ choke until engine runs smoothly, then advance to NO CHOKE position.
5. Engage Spader clutch lever (lever pulled up); refer to Figure 14. Then disengage several times to check the clutching action of the belts. If it is not clutching properly, see "Belt Adjustment," page 8.
6. To stop Spader and engine, release Spader clutch control lever and move throttle control lever to STOP position.

OPERATION INSTRUCTIONS

1. Since the Spader is run at full throttle at all times, we feel a break-in period is necessary for longer Spader life. Run engine at $\frac{1}{2}$ throttle for approximately 2 hours before actual tillage.

IMPORTANT: BE EXTREMELY CAREFUL TO PREVENT DIRT OR FOREIGN PARTICLES FROM ENTERING THE ENGINE CRANKCASE OR TRANSMISSION WHEN CHECKING OIL LEVEL.

2. Change engine oil after the first 5 hours of operation. Always drain the oil while engine is warm. Remove drain plug at rear of engine and tilt Spader backward to completely drain all old oil. Replace drain plug. Be sure Spader is level and fill to overflowing with S.A.E. 30 motor oil, MS,SC,SD or SE. Oil capacity: Approximately 2-3/4 pints.

3. Check oil in transmission at the time of the initial engine oil change and prior to each use. Remove pipe plug located on R.H. side of transmission. Oil level must be even with bottom of plug. If necessary, add Allstate S.A.E. 30 motor oil for service, MS,SC,SD or SE. Replace pipe plug.

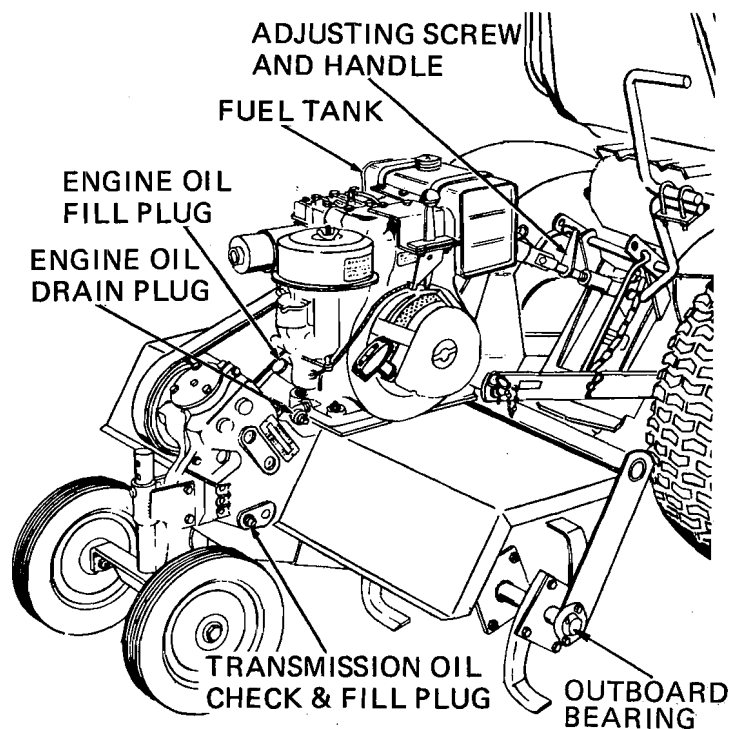

FIG. 7

4. Start Spader engine.
5. Start tractor engine.
6. Engage clutch on Spader and move throttle lever to full throttle position
7. Place tractor in slowest forward speed with throttle at idle speed or just above and engage tractor clutch.
8. Lower Spader.

KNOW THE CONTROLS AND HOW TO STOP QUICKLY—READ THE OWNER'S MANUAL.

TILLING DEPTH

1. The tilling depth is controlled by the gauge wheels shown above and to some extent by the adjusting screw and handle. Refer to Figure 8. When deeper tilling is required, the gauge wheels must be raised. Wheels must be lowered for shallower tilling. Remove retainer spring from drilled rivet. Adjust gauge wheels up or down as desired and replace rivet and retainer spring.

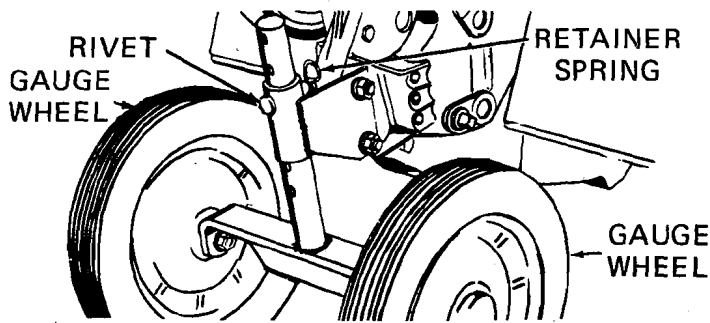

FIG. 8

NOTE: Each hole will raise or lower gauge wheels 1 inch. Spader can be levelled if necessary by turning adjusting screw and handle, shown in Figure 7. The adjusting screw and handle also control tilling depth. Shortening adjusting screw will increase tilling depth, and lengthening adjusting screw will decrease tilling depth. However, try to keep Spader level at all times.

2. The most efficient tillage is obtained when Spader engine is fully loaded. The sound of Spader engine will tell you. When Spader engine is lightly loaded, raise gauge wheels to increase tilling depth. If engine seems to be overloaded or stalls out, lower gauge wheels for shallower tilling.
3. Operate Spader engine at full throttle and operate tractor in slowest forward speed, with tractor engine at idle speed or just above idle. You will soon learn the proper combination of tilling depth and speed for good tillage.
4. Soil conditions will determine how deep Spader can penetrate on the first pass. In extremely hard ground, several passes may be necessary to till to a depth of 6 inches, while in soft ground, Spader may penetrate to a depth of 6 inches in the first pass.
5. **NOTE:** Tractors equipped with speed changer: It is necessary to purchase a slow-speed pulley to slow down ground travel. If 3-point hitch does not have two holes in lever crank on lever, drill another 17/32-inch hole in each lever crank, 3/4 inch in from present hole center.

CULTIVATING

Set gauge wheels so that Spader will penetrate soil to a depth of 2 to 3 inches. The Spader engine should be run at full throttle, except when cultivating small plants, a slower engine speed is necessary to prevent burying the plants.

MAINTENANCE AIR CLEANER

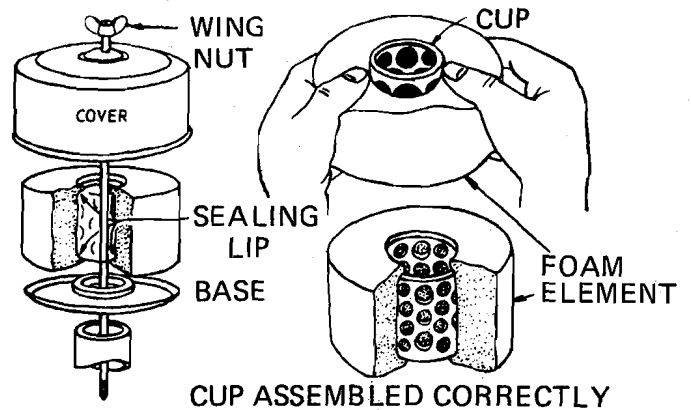

FIG. 9

Clean and re-oil the air cleaner frequently (every few hours under extremely dusty conditions). Clean and re-oil at least every 25 hours under normal conditions.

1. Remove wing nut and cover.
2. Lift off foam element from base.
3. Push down foam element as shown, and pull out cleaner cup.
4. a. Wash foam element in liquid detergent and water to remove dirt.
b. Wrap foam in cloth and squeeze dry.
c. Saturate foam with fresh engine oil. Squeeze to remove excess oil.
- d. Put air-cleaner cup inside element. Be sure sealing lip is over end of cup (top and bottom).
5. Reassemble parts as shown. Screw wing nut down tight.

IMPORTANT: NEVER RUN ENGINE WITH AIR CLEANER REMOVED.

DUSTY CONDITIONS

Service engine regularly in dusty conditions. Air filter should be cleaned every day and change engine oil every 15 hours of operation. In extreme dusty conditions, clean air filter every 4 hours and change engine oil every 10 hours of operation. The service given engine greatly affects the life of the engine.

KEEP THE ENGINE CLEAN AND FREE FROM ACCUMULATIONS OF GRASS, LEAVES, SPILLED OIL OR GASOLINE, ETC. THE PRESENCE OF SUCH COMBUSTIBLE MATERIALS MAY CAUSE FIRE.

STARTER AIR SCREEN

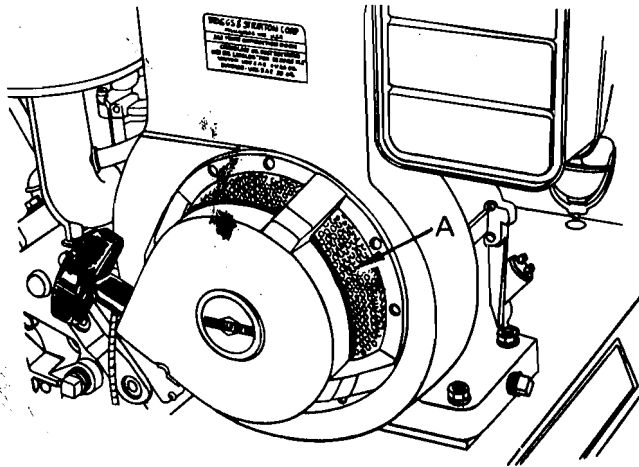

FIG. 10

Keep screen (A) around starter clean. Air is brought in through screen to cool engine. Clean with a brush frequently.

CYLINDER FINS

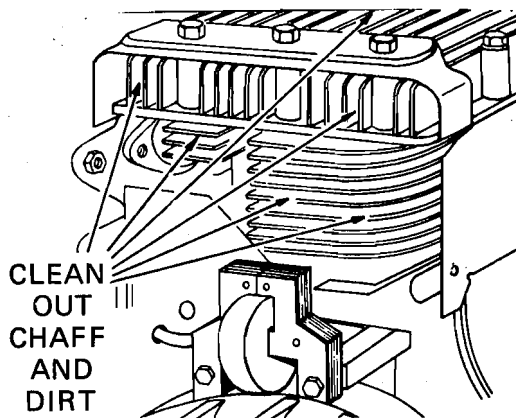

FIG. 11

1. Grass or chaff may clog system after prolonged service. Continued operation with a clogged cooling system causes severe overheating and possible engine damage.

2. Remove blower housing and clean regularly.

KEEP ENGINE IN GOOD OPERATING CONDITION AND KEEP SAFETY DEVICES IN PLACE.

CARBURETOR

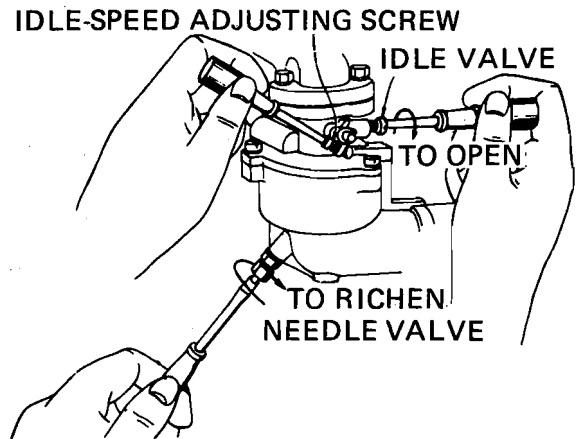

FIG. 12

1. Minor carburetor adjustment may be required to compensate for differences in fuel, temperature, altitude and load.

2. TO ADJUST CARBURETOR: Turn needle valve clockwise until it just closes.

VALVE MAY BE DAMAGED BY TURNING IN TOO FAR. TIGHTEN BY HAND ONLY.

3. Now open needle valve 1-1/8 turns counterclockwise. Close idle valve in same manner and open 1-1/8 turns. This initial adjustment will permit the engine to be started and warmed up prior to final adjustment.

4. FINAL ADJUSTMENT: Turn needle valve in until engine misses (lean mixture), then turn it out past smooth-operating point until engine runs unevenly (rich mixture). Now turn needle valve to the midpoint between rich and lean so the engine runs smoothly. Hold throttle at idle position and set idle-speed adjusting screw until fast idle is obtained (1750 RPM). Move throttle control lever to slow position and turn idle valve in (lean) and out (rich) until engine idles smoothly. Then reset idle-speed adjusting screw so that engine idles at 1750 RPM. Move throttle control lever to fast position—engine should accelerate without hesitation or sputtering. If engine does not accelerate properly, the carburetor should be readjusted to a slightly richer mixture.

SPARK PLUG

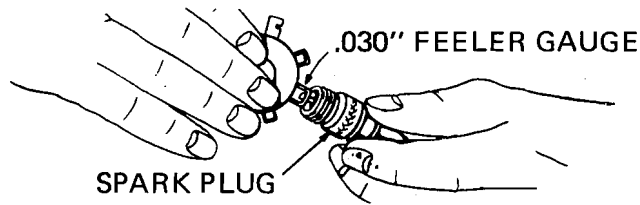

FIG. 13

Clean and reset gap at .030 inch every 100 hours of operation. Blast-cleaning of spark plugs in machines that use abrasive grit is NOT recommended. Spark plugs should be cleaned by scraping or wire brushing and washing with a commercial solvent or gasoline. Should spark plug need replacing, use Champion CJ-8 or equivalent.

DISENGAGE POWER TO ANY ATTACHMENT, STOP ENGINE AND DISENGAGE SPARK PLUG BEFORE MAKING REPAIRS OR ADJUSTMENTS.

ENGINE LUBRICATION

CHECK OIL LEVEL REGULARLY—AFTER EACH 5 HOURS OF OPERATION. STOP ENGINE AND WAIT SEVERAL MINUTES BEFORE CHECKING OIL LEVEL. BE SURE OIL LEVEL IS MAINTAINED AND SPADER IS ON LEVEL GROUND.

1. Change oil after first 5 hours of operation. Thereafter, change oil every 25 hours of operation. Remove oil drain plug and drain oil while engine is warm.

NOTE: THE BEST TIME TO DRAIN OIL IS AT THE END OF A DAY'S OPERATION, AT WHICH TIME THE OIL IS HOT AND ALL DIRT AND FOREIGN MATERIAL ARE SUSPENDED IN THE OIL.

2. Refill engine crankcase with oil as instructed on page 2. Capacity: 2¾ pints. Nothing should be added to the recommended oil. Check oil level after each 5 hours of operation and add oil, if necessary, to bring to correct level.

TRANSMISSION LUBRICATION

1. **NOTE:** The oil level of the transmission should be checked at the time of the initial engine oil change (after 5 hours of

operation). Remove fill plug (refer to Figure 7), located at R.H. side of transmission. Oil level must be even with bottom of plug. Add oil, if necessary. Use S.A.E. 30 motor oil for service, MS or equivalent. Replace fill plug.

2. **IMPORTANT:** It is not necessary to change the oil in this Spader transmission. If, for any reason, it must be changed, oil capacity is 1 1/4 quarts of S.A.E. 30 motor oil for service, MS or equivalent.

OUTBOARD BEARING LUBRICATION

1. There are two (2) grease fittings on your Spader. One at each outboard bearing. Use Multipurpose Pressure Gun Grease. Fill until grease comes out the inner end of bearings. Grease every eight (8) hours. (Page 5, Fig. 7)

BELT ADJUSTMENT

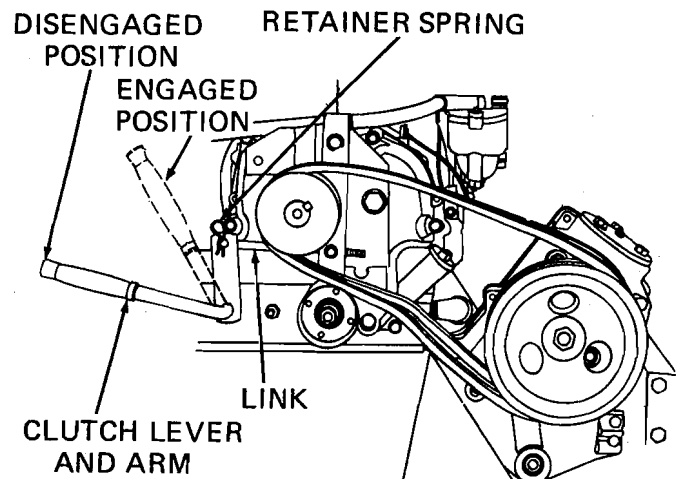

FIG. 14 BELT GUARD REMOVED FOR ILLUSTRATION

The clutch is a belt-tightener type. Belts should be just tight enough to prevent slippage. To tighten belts, remove retainer spring securing belt-tightener link to lever and arm, and turn link in a counterclockwise direction, when standing in front of Spader, one turn at a time, until belts no longer slip. Belts that are too tight stretch, require more H.P., and put more strain on bearings.

BELT REPLACEMENT

1. Remove three bolts holding belt guard to Spader.
2. Remove old belts.
3. Install new belts so that lower sides of belts are above idler, as shown.
4. Replace belt guard.

STORAGE

Engines to be stored over 30 days should be completely drained of fuel to prevent gum deposits forming on essential carburetor parts, fuel filter, fuel lines and tank.

1. Drain fuel tank completely and clean fuel filter.
2. Operate engine until gasoline in carburetor is completely consumed.
3. While engine is still warm, drain oil from crankcase. Refill with fresh oil.
4. Remove spark plug, pour one ounce (2 or 3 tablespoons) of S.A.E. 30 motor oil into cylinder and pull starter rope slowly to distribute oil. Replace spark plug.
5. Clean dirt and chaff from cylinder head fins, blower housing and entire Spader.

IF ROTO-SPADER IS TO BE STORED FOR AN EXTENDED PERIOD, EMPTY THE GASOLINE-STORAGE CONTAINER, EITHER DISCARDING THE GASOLINE IN A SAFE PLACE OR USING IT IN OTHER GASOLINE-POWERED EQUIPMENT FOR WHICH IT MAY BE SUITED.

STORE YOUR SPADER INSIDE A DRY, WEATHER-PROOF BUILDING.

GENERAL

1. Just as your automobile needs professional mechanical maintenance from time to time, so does your air-cooled engine. Periodic replacement of the spark plug (every 100hrs) is made necessary by NORMAL use.
2. Professional air-cooled-engine service is as close as your nearest Sears service department.
3. A yearly check-up or tune-up by a Sears service department is a good idea to avoid breakdowns or delays. Do it each fall; then, you're ready for spring. We even prepare it for storage for you.

MAJOR REPAIRS SHOULD NOT BE ATTEMPTED UNLESS YOU HAVE THE PROPER TOOLS AND A THOROUGH KNOWLEDGE OF THIS MACHINE.

Sears, Roebuck and Co. or Simpsons-Sears, Ltd. in Canada reserves the right to make any changes in design or improvements without imposing any obligation to install the same upon its items heretofore manufactured.

repair parts

ROTO-SPADER ATTACHMENT—MODEL NO. 917.251880

ENGINE AND TINES

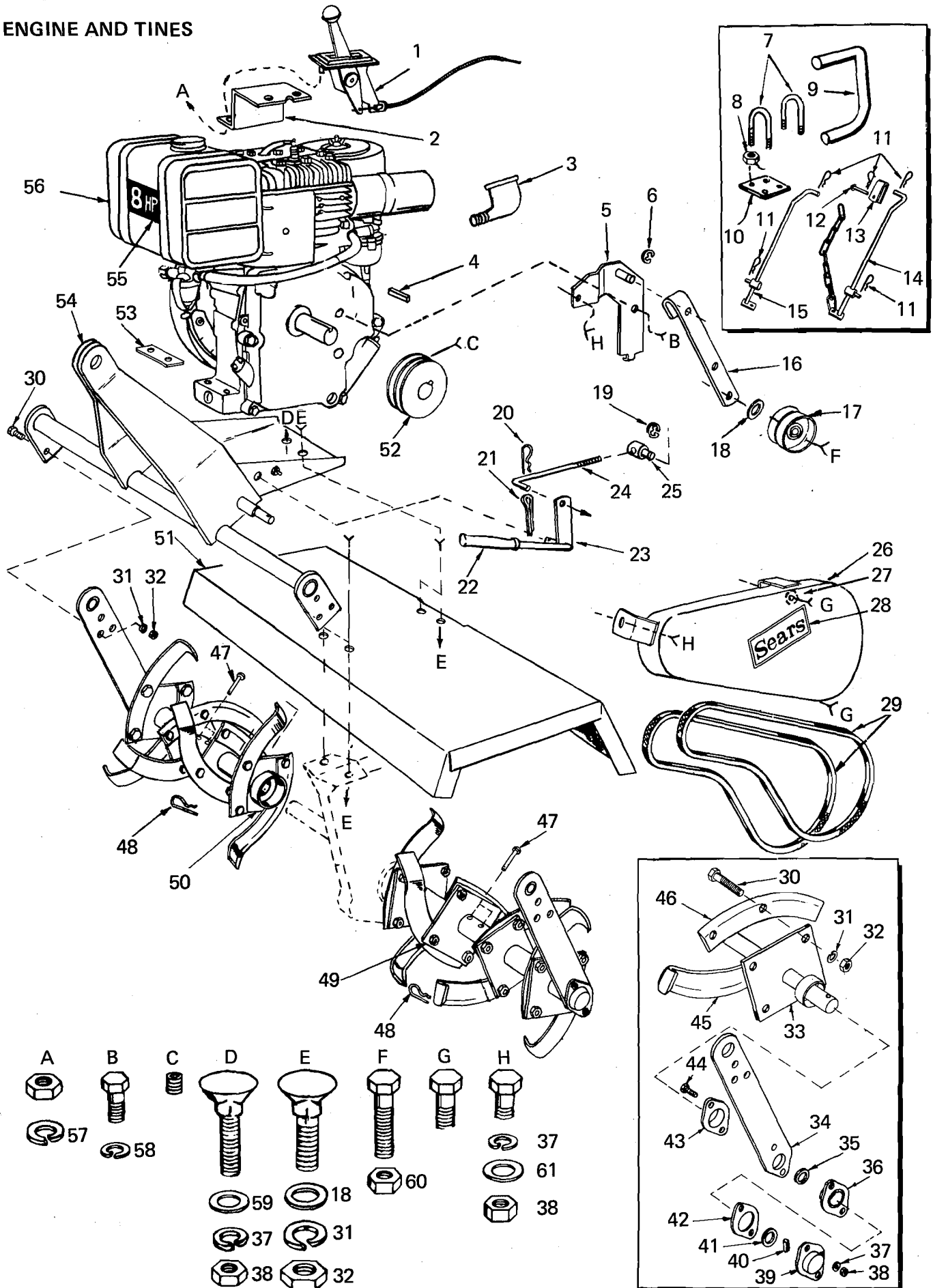

repair parts

ROTO-SPADER ATTACHMENT—MODEL NO. 917.251880

TRANSMISSION AND GAUGE WHEELS

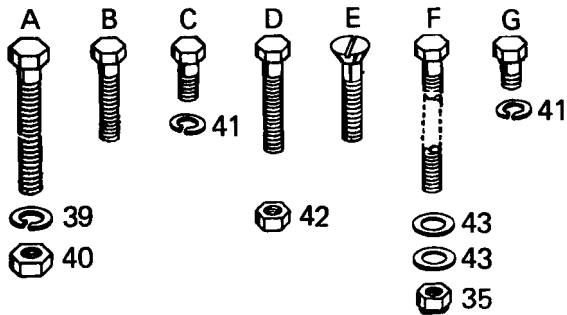
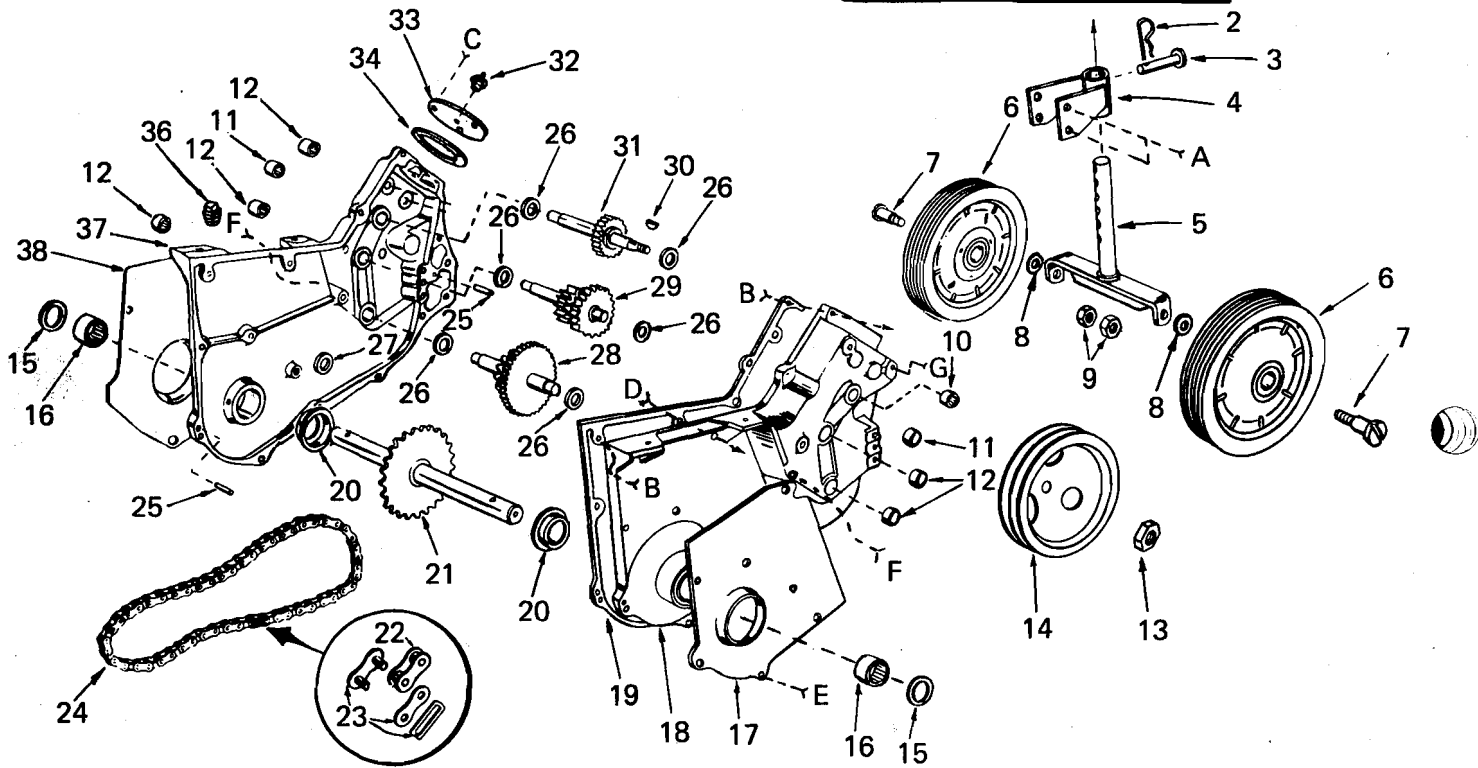
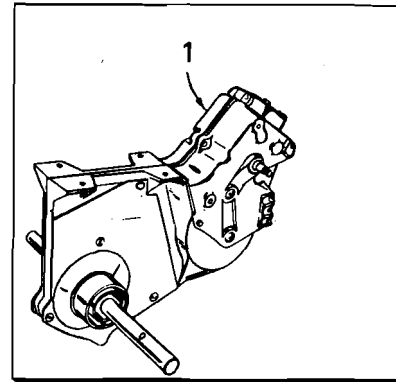

repair parts

ROTO-SPADER ATTACHMENT—MODEL NO. 917.251880

TRANSMISSION AND GAUGE WHEELS

KEY NO.	PART NO.	DESCRIPTION	KEY NO.	PART NO.	DESCRIPTION
1	634A562	Transmission	29	634A58	1st Reduction Shaft and Gears
2	4939M	Retainer Spring	30	9858M1	Woodruff Key 3/16 x 5/8
3	4929H	Drilled Pan Head Rivet 3/8 x 3/4	31	634A57	Input Shaft and Pinion
4	634A61	Gauge Wheel Sleeve and Brackets	32	5855H	Relief Valve
5	634A559	Gauge Wheel Adjusting Shaft and Brackets	33	6672H	Gear Shift Cover
6	3474R	Wheel	34	4913H	Gasket
7	4898H	Shoulder Bolt	35	1685H	Locknut 5/16-18
8	1557P	★Washer 13/32 x 13/16 x 11 Ga.	36	4002P	Pipe Plug 1/2 14 N.P.T.
9	514P	★Locknut	37	624A57	Gear Case and Bearings R.H. Half
10	3136R	Needle Bearing	38	4878H1	Gear Case Shield R.H.
11	6677H	Needle Bearing Shell	39	1004P	★Lockwasher 3/8
12	4895H	Needle Bearing	40	501P	★Hex Nut 3/8-16
13	9204H	Hex Nut 1/2-20	41	1003P	★Lockwasher 5/16
14	3472R	Input Sheave	42	504P	★Hex Nut 5/16-18
15	4910H	Oil Seal	43	7850H	Spacer
16	4896H	Needle Bearing	A	3030P	★Hex Bolt 3/8-16 x 2-1/4
17	4877H1	Gear Case Shield L.H.	B	5586P	Hex Hd. Roll Lok Tapping Screw 5/16-18 x 1-1/2
18	624A56	Gear Case and Bearings L.H. Half	C	3010P	★Hex Bolt 5/16-18 x 3/4
19	2601R	Gasket	D	3015P	★Hex Bolt 5/16-18 x 2
20	4870H	Thrust Cap	E	5585P	Flat Hd. Slotted Roll Lok Tapping Screw 5/16-18 x 1-1/2
21	634A555	Tine Shaft and Sprocket	F	3018P	★Hex Bolt 5/16-18 x 6
22	4950H	Roller Link	G	3008P	★Hex Bolt 5/16-18 x 1/2
23	4949H	Connecting Link			
24	2600R	Roller Chain			
25	9880M	Dowel Pin			
26	1370H	Thrust Bearing Race			
27	4912H	Gasket			
28	634A59	2nd Reduction Shaft and Gears			

★ STANDARD HARDWARE--PURCHASE LOCALLY

repair parts

8 H.P. ENGINE MODEL NUMBER 190402

TYPE NUMBER 0858-01

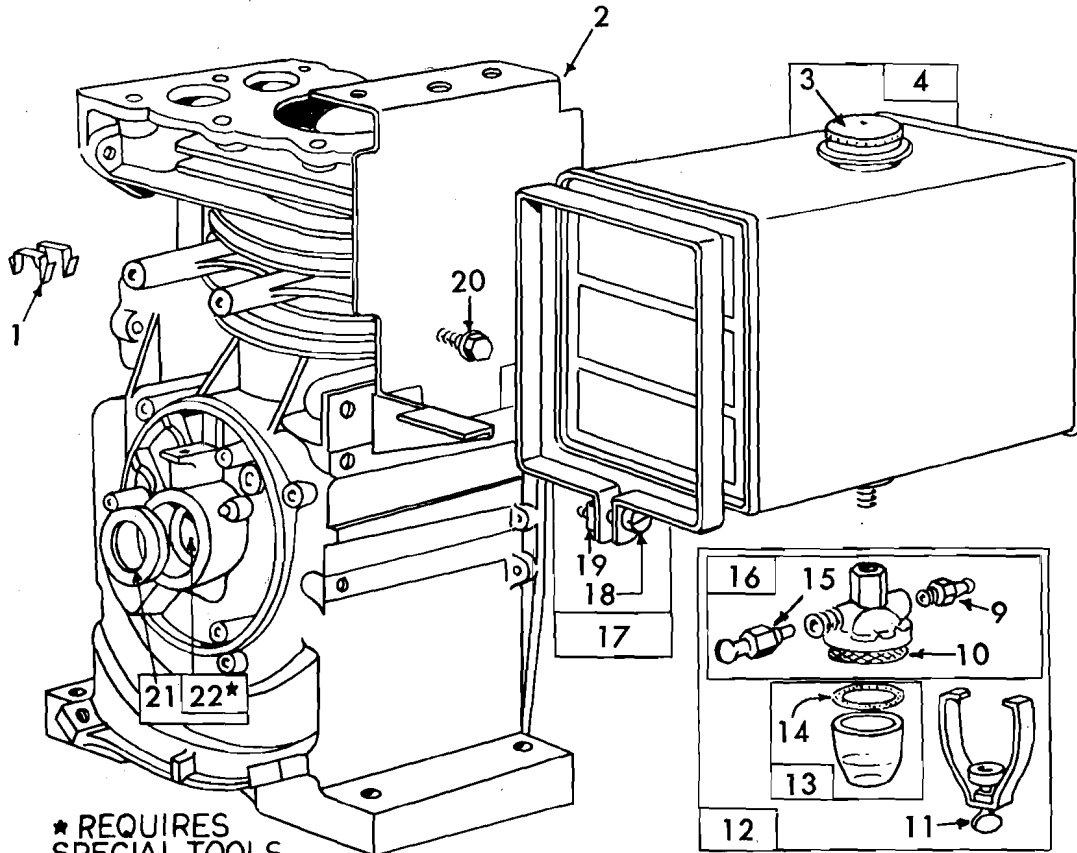

★ REQUIRES SPECIAL TOOLS FOR INSTALLING

23 CARBURETOR OVERHAUL KIT

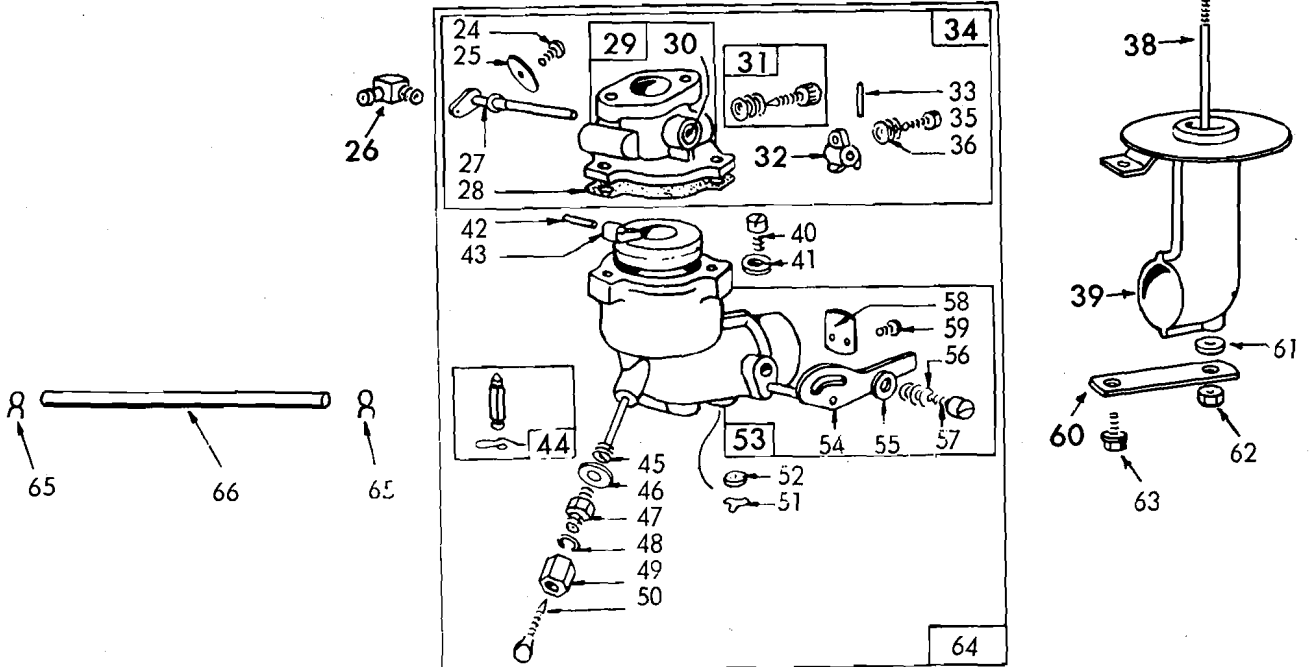

repair parts

8 H.P. ENGINE MODEL NUMBER 190402

TYPE NUMBER 0858-01

KEY NO.	PART NO.	DESCRIPTION	KEY NO.	PART NO.	DESCRIPTION
1	221907	Clip-Wire	35	91920	Screw-Mach. Fil. Hd. No. 8-32 x 5/8
2	221935	Bracket-Fuel Tank	36	26157	Spring-Throttle
3	69221	Cap-Fuel Tank	37	93453	Nut-Wing
4	290816	Tank Assy. - Fuel	38	230768	Stud-Air Cleaner
5	221468	Cover-Air Cleaner	39	390311	Pipe Assy.-Air Cleaner
6	280001	Cup-Air Cleaner	40	90746	Screw-Mach., Fil. Hd. No. 10-32 x 5/8
7	270093	Element-Air Cleaner	41	92290	Washer-Lock No. 10 x 1/16 x 3/64
8	390400	Cleaner Assy.-Air	42	† 230896	Pin-Float Hinge
9	230318	Connector-Fuel Pipe	43	99333	Float-Carburetor
10	22547	Screen-Fuel Filter	44	299096	Valve-Fuel Inlet
11	99665	Yoke-Fuel Filter	45	† 390395	Nozzle-Carburetor
12	295984	Filter Assembly-Fuel	46	† 68667	Gasket-Nozzle
13	298683	Bowl-Fuse Filter	47	23117	Retainer, Needle Valve
14	*68477	Gasket-Fuel Filter	48	68677	Packing, Needle Valve
15	295913	Valve-Fuel Shut-off	49	23118	Nut, Needle Valve Packing
16	296005	Cover Assembly-Fuel	50	230009	Valve Needle
17	291367	Strap Assy.-Fuel Tank	51	220521	Retainer-Carburetor
18	91257	Screw-Mach. Fil. Hd. 1/4-20 x 1 1/2	52	27590	Drain Filter
19	90970	Nut-Square 1/4-20	53	390403	Filter-Carburetor Drain
20	93535	Screw-Sems	54	298875	Body Assy.-Lower Carburetor
21	294606	Seal-Oil	55	62899	Shaft And Lever Choke
22	295962	Bushing-Cylinder Note: Requires special tools for installation	56	26155	Washer - Choke Lever
23	295938	Carburetor Over Haul Kit	57	23123	Spring - Choke Lever
24	93038	Screw-Throttle and Choke Valve Mfg. Sem	58	93038	Screw - Choke Lever
25	62940	Valve-Throttle	59	62872	Screw-Throttle and Choke Valve Mtg. Sem
26	67218	Connector-Fuel Pipe	60	222150	Valve-Choke
27	298826	Shaft and Lever-Throttle	61	66648	Strap-Air Cleaner Pipe
28	† 27918	Gasket-Carburetor Body	62	92129	Gasket-Air Cleaner Stud
29	390503	Body-Upper Carburetor	63	93158	Nut-Hex 1/4-28
30	23108	Bushing-Throttle Shaft	64	390323	Screw-Sem
31	† 292681	Valve Assembly-Carburetor Idle	65	93053	Carburetor Assy.
32	61967	Stop-Throttle	66	299942	Clamp-Fuel Pipe
33	93043	Pin-Throttle Stop			Pipe-Fuel
34	390404	Body Assembly-Upper Carburetor			

*Included in gasket set part no. 299577

† Included in carburetor overhaul kit part no. 295938

repair parts

8 H.P. ENGINE MODEL NUMBER 190402

TYPE NUMBER 0858-01

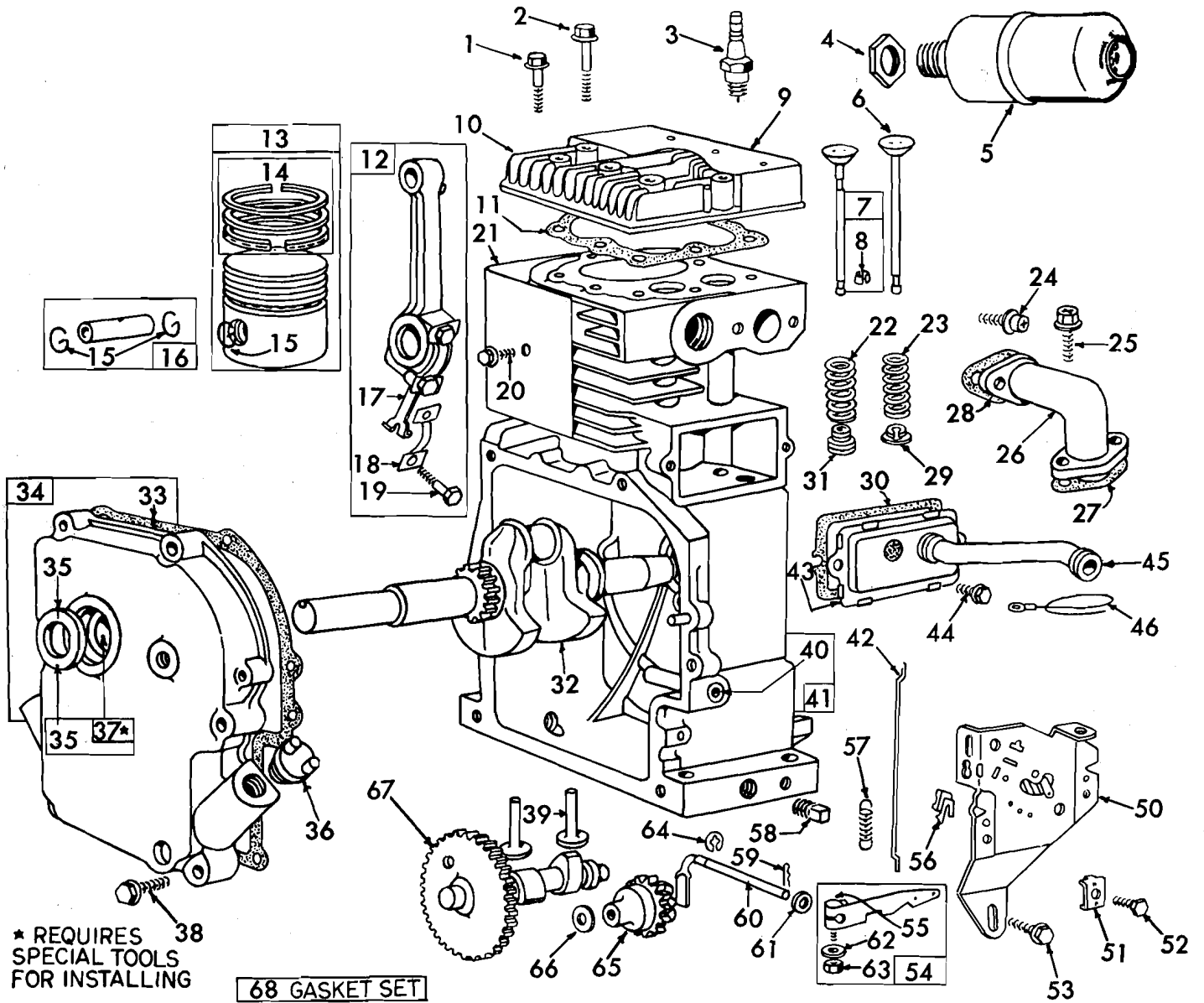

repair parts

8 H.P. ENGINE MODEL NUMBER 190402

TYPE NUMBER 0858-01

KEY NO.	PART NO.	DESCRIPTION	KEY NO.	PART NO.	DESCRIPTION
1	93210	Screw-Cylinder Head (2-9/32 long)	22	26828	Spring-Exhaust Valve
2	93211	Screw-Cylinder Head (2-9/16 long)	23	65906	Spring-Intake Valve
3	298809	Plug-Spark Note: Spark plugs 298809 use ignition cable terminal no. 221798	24	93208	Screw-Intake Elbow Mounting Sem.
4	91242	Locknut- Muffler	25	93128	Screw-Carburetor Mounting Sem.
5	390578	Muffler-Exhaust	26	211812	Elbow-Intake
6	261055	Valve-Intake	27	* 270684	Gasket-Intake Elbow
7	390419	Valve-Exhaust	28	* 27828	Gasket-Intake Elbow Mtg.
8	93630	Retainer-Exhaust Valve Rotocoil (2)	29	221596	Retainer-Intake Valve
9	221901	Cover-Cylinder Head	30	* 27803	Gasket-Valve Cover
10	211778	Head-Cylinder	31	292260	Rotocoil-Exhaust Valve
11	* 270430	Gasket-Cylinder Head	32	261077	Crankshaft
12	390401	Rod Assy.-Connecting Note: For connecting rod with .020" undersize crankpin bore-order no. 390773	33	* 27750	Gasket-Crankcase cover 1/64" thick
13	390347	Piston Assembly Std.	34	299167	Cover Assy.-Crankcase
	390348	Piston Assy. .010" O.S.	35	298423	Seal-Oil
	390349	Piston Assy. .020" O.S.	36	66768	Plug-Oil Filler
	390350	Piston Assy. .030" O.S.	37	295964	Bushing-Crankcase Cover Note: Requires special tools for installation
	Piston ring sets	Note: For chrome ring set standard size order no. 299743	38	93585	Screw-Crankcase cover mounting sem.
14	299569	Ring Set-Piston-std. Consists of 211637 piston ring comp. top std. 211636 piston ring comp. center std. 211635 piston ring oil std.	39	260933	Tappet-Valve
	299570	Ring Set-Piston-.010" O.S. Consists of 211649 piston ring comp. top .010" O.S. 211650 piston ring comp. center .010" O.S. 211651 piston ring oil .010" O.S.	40	230843	Bushing-Governor Shaft
	299572	Ring Set-Piston-.030" O.S. Consists of 211657 piston ring comp. top .030" O.S. 211658 piston ring comp. center .030" O.S. 211659 piston ring oil .030" O.S.	41	390399	Cylinder Assembly
15	68546	Lock-Piston Pin	42	260872	Link-Governor
16	295840	Pin Assy.-Piston-Std.	43	390321	Breather Assembly
	295841	Pin Assy.-Piston.005" O.S.	44	93536	Screw-Sem
17	222113	Dipper-Connecting Rod	45	67068	Tube-Breather
18	222114	Lock-Conn. Rod Screw	46	299500	Wire-Ground
19	92659	Screw-Connecting Rod	50	390670	Plate-Governor Control
20	93163	Screw-Cylinder Shield Mtg. Sem.	51	221535	Clamp-Casing
21	221898	Shield-Cylinder	52	93496	Screw-Sem.
			53	93535	Screw-Sem.
			54	299165	Lever Assy.-Governor
			55	92613	Bolt-Governor Lever
			56	297472	Switch-Stop
			57	261194	Spring-Governor
			58	91084	Plug-Oil Drain
			59	93306	Cotter-Hair Pin
			60	230842	Crank-Governor
			61	221559	Washer-Spacer
			62	220680	Washer
			63	90356	Nut-Hex 10-24
			64	93307	Retainer-E-Ring
			65	297656	Gear-Governor
			66	221551	Washer-Thrust
			67	210728	Gear-Cam
			68	299577	Gasket Set

* Included in gasket set Part no. 299577

repair parts

8 H.P. ENGINE MODEL NUMBER 190402

TYPE NUMBER 0858-01

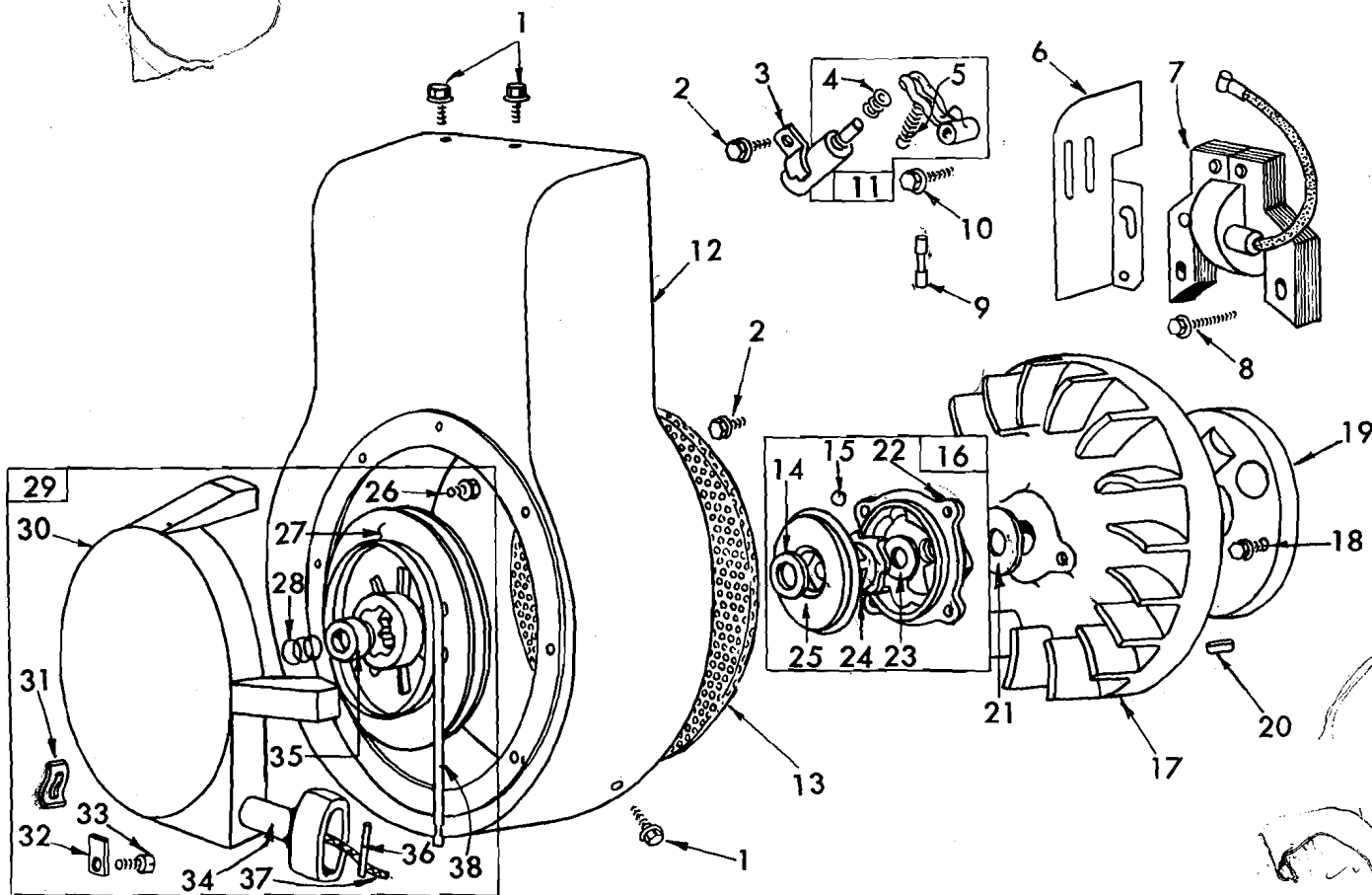

KEY NO.	PART NO.	DESCRIPTION	KEY NO.	PART NO.	DESCRIPTION
1	93158	Screw-Sem.	19	222117	Cover-Breaker Point
2	93042	Screw-Sem.	20	61760	Key-Flywheel
3	220477	Clamp-Condenser	21	220865	Washer-Spring
4	260374	Spring-Connector	22	221383	Housing-Rewind Starter Clutch
5	26018	Spring-Breaker Arm	23	66718	Washer-Starter Clutch Thrust
6	221760	Guide-Air	24	298799	Ratchet-Rewind Starter Clutch
7	298968	Armature Assembly	25	221653	Washer-Retainer
8	93381	Screw-Armature Mtg. Sem	26	93067	Screw-Rewind Starter Housing Mtg. Sem.
9	65704	Plunger-Breaker Point	27	295871	Pulley-Rewind Starter
10	93381	Screw-Breaker Arm Mounting Sem	28	260414	Spring-Ratchet
11	294628	Breaker points and condenser set. Note: 299061 ignition kit includes 294628 point set 65704 plunger and 61760 key-flywheel.	29	295001	Starter Assy.-Rewind
12	299853	Housing-Blower	30	295272	Housing-Rewind Starter
13	221796	Screen-Rewind Starter	31	221014	Anchor-Spring
14	68238	Washer-Ratchet Sealing	32	68848	Bumper-Starter Pulley
15	63770	Ball-Clutch	33	93254	Screw-Pulley Bumper Mounting
16	298798	Clutch Assy.-Rewind Starter	34	66728	Grip-Starter Rope
17	298260	Flywheel-Magneto	35	230543	Adapter-Ratchet Spring
18	93014	Screw-Sem	36	230228	Pin-Starter Grip
			37	66564	Rope-Rewind Starter
			38	294303	Spring-Rewind Starter

Sears owners manual

MODEL NO.

917.251880

**How to Order
Repair Parts**

333-7159

333 2123

The Model Number will be found on a plate attached to the R.H. side of the transmission. Always mention the Model Number when requesting service or repair parts for your **ROTO-SPADER ATTACHMENT**

All parts listed herein may be ordered from any **SEARS, ROEBUCK AND CO.** or **SIMPSONS-SEARS LIMITED** retail or catalog store.

WHEN ORDERING REPAIR PARTS, ALWAYS GIVE THE FOLLOWING INFORMATION:

1. PART NUMBER
2. MODEL NUMBER
3. PART DESCRIPTION
4. NAME OF MERCHANDISE

If the parts you need are not stocked locally, your order will be electronically transmitted to a Sears Repair Parts Distribution Center for "expedited handling".



When you buy merchandise from Sears you get an extra something that nobody else can offer . . . Sears Service.

Original Document Scan
Provided By:
WheelHorse.Org

Sears, Roebuck and Co., Chicago, Ill. 60684 U.S.A.
and Simpsons Sears Limited, Toronto